

TECHNICAL DATA - DATI TECNICI

Average Output Power	Potenza media di uscita	10 W	12 W	20 W	40 W	50 W
Wavelength [nm]	Lunghezza d'onda [nm]	1064	1070			
Laser technology	Tecnologia laser	YVO4	Yb			
Repetition Rate Range [KHz]	Frequenza di lavoro [KHz]	2-100	2-1000	2-200	2-1000	50-200
Pulse Width [ns]	Lunghezza d'impulso [ns]	35	9 - 250	200	9 - 250	200
Max Pulse Energy [mJ]	Energia massima [mJ]	0,7	0,6	0,8	1,25	1
M2 ≤	M2 ≤	1,8	1,6	1,5	3	2
Beam spot diameter f160 [µm]	Diametro laser f160 [µm]	20	16	20	30	25
Guide Laser	Guida laser	Class 2M Red Laser Diode, =650 nm, 2 mW				
Temperature Range	Temperatura	Operative 10°C to 35°C, Storing 0 to 50 °C				
Cooling System	Raffreddamento	Forced-airod cooling				
Power Supply	Alimentazione	230 V, ± 10 %, 50 /60 Hz				
Max Power Consumption [W]	Consumo massimo [W]	800 W, 4 A				
Optical Fiber Length	Lunghezza fibra ottica	3m SMA connector				
Languages available	Lingue disponibili	Italian, English, German, Spanish, French, Japanese, Chinese, Portuguese, Russian				

laser technology at your hand

Offices and Services in the WORLD

APLAI SRL - Laser & Automations
via dell'Artigianato, 26 - 36060 Romano d'Ezzelino (VI) - Italy
ph. +39 0424 510050 - fax +39 0424 514035 - info@aplai.it - www.aplai.it

SISMA LASER ESPAÑA, s.l.
Ctra. Castellar n° 541 - 08227 Terrassa - Barcelona - España
ph./fax +34 93 4800635 - info@sismalaser.es - www.sismalaser.es

DUBAI - UAE - DMCC Dubai Metals & Commodities Centre
Bldg. n°3, Ground Floor, Shop n°F02 - ph. +971(4) 3688737 - fax +971(4) 3688738
dubai@sisma.com - www.sisma.com

MOSCA - CSI
109147 - R.F. Moscow - Russia Uliza Voronzovskaia, 35A - Office 509 - 5 Floor
ph +7 (495) 9123824 - fax 007 (495) 9112152 - sisma.moscow@gmail.com

WUXI - CINA
Wuxi, Jiangsu 214071 - China 300 Qinan, Qing Qi Lu, APT 201
ph. +86 5105109595 - fax +865105109595 - wx.sisma@public1wx.js.cn - www.sisma.com

SISMA MESSICO - Sisma Laser Systems, S.A. DEC.V.
Parque Rio Grijalva 25, casa 3, Col. Cuauhtemoc, Delegacion Cuauhtemoc - CP. 06500, Mexico D.F., Mexico
ph +52 5552560344 - fax +52 55 52867784 - diego.sisma@gmail.com - www.sisma.com

SISMA FRANCE sarl
13 Rue Crespin du Gast - 75011 Paris, France
ph. +33 155283620 - fax +33 149230122 - sisma.france@orange.fr - www.sisma-france.fr

SISMA LASER - DE
Neumeyerstrasse 48 - 90411 Nurnberg - Germany
ph. +49 (911) 5676947 - mobile +49 (151) 41928809 - webmaster@sisma-laser.de - www.sisma-laser.de

SISMA CENTRO SRL
via P. Gobetti, 23 - 52100 Arezzo - Italy
ph. +39 0575 250960 - fax +39 0575 250402 - info@sismacentro.it - www.sismacentro.it

SISMA DO BRASIL
Av. Alexandre Milani 281 - Bairro Caxambu - Jundai - SP - CEP 13218-650 - Brasil
ph. +55 11 4584.6624 - fax +55 11 7074.7705 - sisma@sismadobrasil.com.br

SAO PAULO - MOURA REPRESENTACOES
José Paulino, 226 Blocco D - Andar Sala 1012 Bom Retiro - 01120-000 - Sao Paulo, Brasil
ph. +55 11 33618661 - fax +55 11 33618661 - mourarep@mourarep.com.br

PORTO ALEGRE - SISMA LASER EQUIPAMENTOS DE ALTA TECNOLOGIA LTDA.
Rua Euclides Moura 121 - 906380-070 PORTO ALEGRE - Brasil
ph. +55 51 30238521 - fax +55 51 30451521 - mobile +55 51 99874413 - rodriguez.sisma@gmail.com

SISMA S.p.A.
via dell'Industria, 1
36013 Piovene Rocchette (VI) Italy
tel. (+39) 0445 595511
fax (+39) 0445 595595
info@sisma.com
www.sisma.com

sisma



OEM series

sisma

laser

OEM series

OEM | OEM plus



OEM 10W

OEM 12W

OEM 20W

OEM 40W

OEM 50W

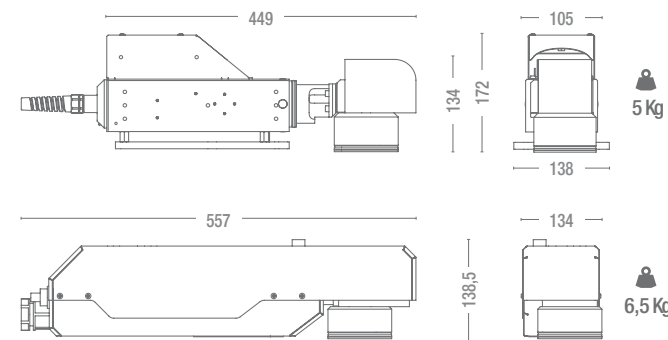

Our new "OEM" and "OEM PLUS" laser series are able to mark and engrave on all types of metal material and most of plastic ones and are equipped with a flexible software especially for creating and marking different types of data, bar codes and matrix data. It's also easy to import and mark all types of files like SVG, DXF, BMP, JPG, HTML and PLT.

Lasers can be supplied with an integrated Embedded PC (standard on "OEM" version) or with an external one and are available in two versions: the first, with "OEM" source configuration, suitable for simple marking plane applications and specific for integration on automatic lines; the second with "PLUS" configuration, suitable for all marking applications which need some accessories like the rotating spindle, Z manual axis, plates feeder and guide-plate dragger.

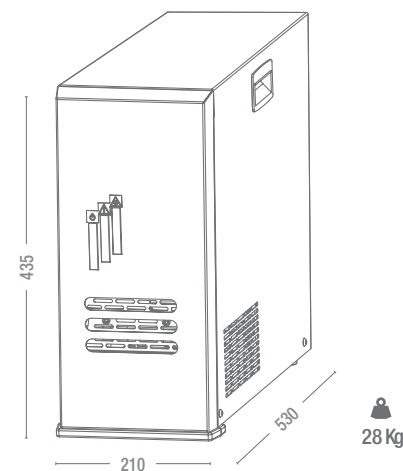

I nuovi Laser della famiglia "OEM" e "OEM PLUS" sono in grado di marcare ed incidere su tutti i tipi di materiale metallico e gran parte delle materie plastiche, sono dotati di software con grande flessibilità soprattutto nella creazione e marcatura di dati variabili, codici a barre e data matrix. Si possono importare e marcare file SVG, DXF, BMP, JPG, HTML e PLT. I Laser possono essere forniti con PC Embedded integrato (standard nella versione "OEM") o con PC esterno. Sono disponibili due versioni: la prima con sorgente in configurazione "OEM"- adatta a semplici applicazioni di marcatura in piano e specifica per integrazioni su linee automatiche, la seconda in configurazione "PLUS" adatta a tutte le applicazioni di marcatura che necessitano dell'utilizzo degli accessori quali il mandrino rotante, asse Z elettrico, alimentatore targhette, traino lastra.

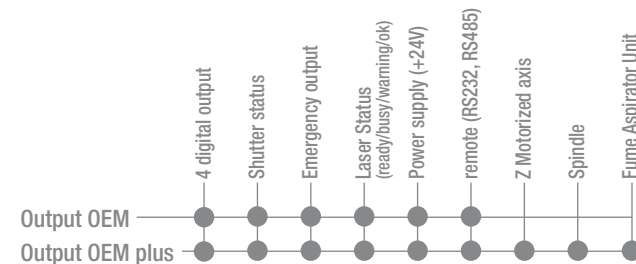
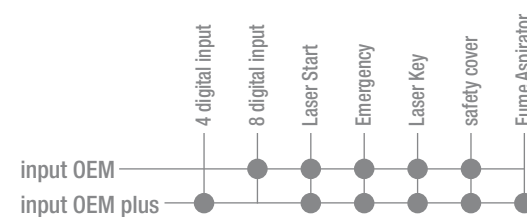

	Z Motorized axis Asse Z Motorizzato	Fumes aspirator Aspirazione fumo	Embedded PC PC interno	3D	Feeding plate Traino lastra	Spindle Mandrino
OEM 10W						
OEM plus 10W						
OEM 12W						
OEM plus 12W						
OEM 20W						
OEM plus 20W						
OEM plus 40W						
OEM plus 50W						