



IQ³⁺ PipeLine Metal Detection

www.loma.com

Versatile, proven metal detection systems for food, and other process industries



- **Versatile** A wide range of pipe diameters and fittings
- **Easy to use** Touch screen - true Variable Frequency detection, adapts to new products in seconds
- **Sensitive** Advanced signal processing provides unsurpassed levels of detection
- **Efficient** Fast acting application specific reject devices minimise product waste
- **Reliable** Heavy duty environmental protection even in the harshest of environments

Metal Detection

X-ray Inspection

Checkweighers

Data Capture

Designed to Survive



IQ³⁺ PipeLine Metal Detection

Finish:	304 stainless steel with bead blast finish	
Pipe Diameters: (nominal bore)	2.5" (57mm) Vacuum Filler applications for strip-down cleaning Typical products - Meat and Sausage	
	2" (48mm) 3" (73mm) 4" (98mm) General pumped applications with CIP cleaning Typical products - Liquids, Emulsions, Slurries and Pastes	
Mounting:	Stand on wheels with Gas Strut height adjustment L-Bracket for fixed installations	
Throughput:	Up to 10T/hr	
Fittings:	2.5" (57mm) Rd80 x 1/4" (6mm), Handtmann Quick Disconnect 2" (48mm), 3" (73mm) and 4" (98mm) Tri-Clamp Quick Release, 3A Bevel	
Adapter Options:	DIN11851, SMS, RJT	
Product Pipe:	Standard or water jacket	
Reject Valves:	Various according to application	
Environmental Protection:	IP 69K Keyboard cover supplied as standard	
Options:	Remote Control Box	LomaEnet
	Beacon Stanchion	Remote Reports
	Serial Link	

Technical Specification

- PVS (Performance Validation Signal) to aid HACCP compliance
- Various communication options to suit plant integration protocols
- Direct transmitter drive to eliminate thermal drift
- High field strength to eliminate external interference and deliver the ultimate in noise free detection
- 32-bit digital signal processing for enhanced contaminant detection
- Hand Filler, Clipper and Linker Applications
- Handtmann (VF50, 80, 100, 200, 300, 608, 610, 612, 616, 620, 622, 628, 630)
- Vemag (HP7C, HP10C, HP15C, HP17C, HP25E, DP10C, DP15C, ROBBY-2)
- Other Manufacturers easily accommodated

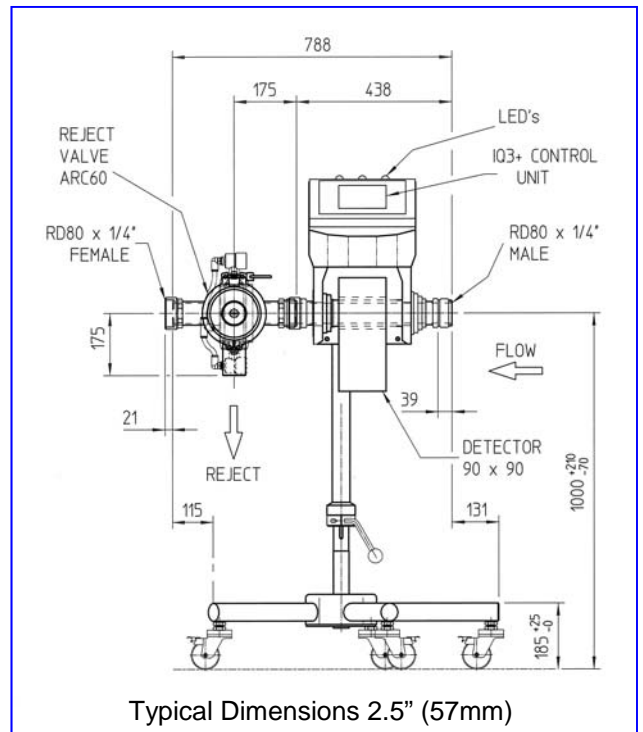

Loma Systems, Summit Ave, Southwood, Farnborough, Hampshire, GU14 0NY

Tel: +44 (0)1252 893300

Fax: +44 (0)1252 513322

Email: sales@loma.co.uk