

Gx350i

Clean. Clear. Coding.

The **Gx350i** Thermal Ink Jet (TIJ) printer is Domino's coding specialist for multi-print head operation, fast data transfer, and challenging controller environments across many industries. The small print heads can be mounted up to 25m from the IP64 rated controller. A 10" touchscreen with intuitive user interface enables easy and error-free operation and data input directly on board.



Easy to integrate

- ◆ Small footprint: easy print head integration and remote controller mounting.
- ◆ EtherCAT option: fast data transfer and precise synchronisation for motion control applications.
- ◆ Track & trace and item level serialisation via Dynamark protocol: 21 CFR Part 11 compliant, audit trail with comprehensive user administration, validation documentation available.



Easy to operate

- ◆ Easy printer operation and monitoring using the touch screen or via web browser.
- ◆ Automatic cartridge recognition and ink parameter setting.
- ◆ For uninterrupted production **AutoSwap** enables cartridge change while printing.
- ◆ Operate 4 print heads from one controller for label height up to 50.8mm or multiple individual applications.



Clean. Clear. Coding.

- ◆ Graphic printing quality on paper, card, plastic, metal, and many other materials.
- ◆ Flexible label design: text, counters, clocks, graphics, logos, barcodes can all be included on the same label.
- ◆ Grade A code readability (ISO 15415) using Domino's inks on high density datamatrix codes*.



Scan for more information

Domino. Do more.



Gx-Series print heads

- ◆ Fit easily with only 15.2 × 5.09 × 2.85cm space requirement and 3 connector options (front, back, top).
- ◆ LED status signals show the print status, e.g. which cartridge needs changing.
- ◆ Maintenance-free: exchange of the ink cartridge replaces all printer wear parts.
- ◆ Error-free coding with automatic ink parameter setting.



Technical specification

Gx350i	
Controller dimensions	Height: 123.9mm (4.87")/Width: 322.4mm (12.69") Depth: 250.7mm (9.87") /Weight: 6.4kg (14.1lbs)
Print head dimensions	Height: 152mm (5.98")/Width: 50.9mm (2") Depth: 28.5mm (1.12") /Weight: 0.22kg (0.48lbs)
Print head cables	3, 6, 12, or 25m
Print heads per controller	Up to 4 print heads for increased message height or individual printing on up to 4 different print positions
Print height	1 print head: 12.7mm 2 print heads: 25.4mm 3 print heads: 38.1mm 4 print heads: 50.8mm
Print speed and resolution	300m/min at 60dpi to 30m/min at 600dpi
External connection options	2 encoders, I/O for beacons, product detects or other; 2 USBs (type A), RS232C, 2x LAN
Power connector	3-way plug
Electrical supply	100-240V AC, 50-60 Hz, 3.5 A
Controller operating temperature	0°-45°C (32°-113°F)
Operating relative humidity	20-80% RH (non condensing, 10°C increase per hour)
Controller finish	Stainless steel
Inks	A range of fast-drying water and solvent-based inks for porous and non-porous substrates, black, colours and specialist inks
i-Techx features	Automatic ink cartridge detection, automatic ink parameter setting, automatic ink level recording
Communication	Ethernet / Dynamark protocol, EDC (serial, TCP, USB) optional: EtherCAT protocol
User interface	QuickStep via 10" touch screen or customer HMI

* module size 40x40, ≤ 169 characters

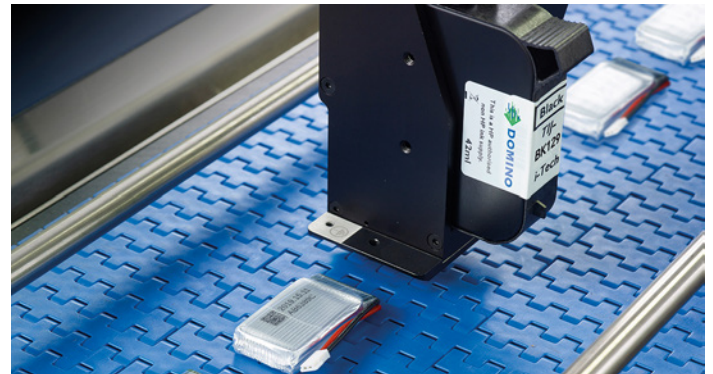

User interfaces

Domino offers a range of interfaces on the printer, on a PC and directly to our Cloud based dashboards

- ◆ Easy operation using the **QuickStep** interface on the touchscreen or via web browser on your HMI.
- ◆ Monitoring screens display live information about the printer; connection to Domino Cloud adds remote monitoring and diagnostics.
- ◆ Access levels can be defined to ensure safe handling.
- ◆ Label creation and editing are simple using the **QuickStep** Label Creator or our PC-based design software.
- ◆ Coding Automation solutions to populate data directly from a database and control changeovers from your ERP or MES system.

Gx350i controller

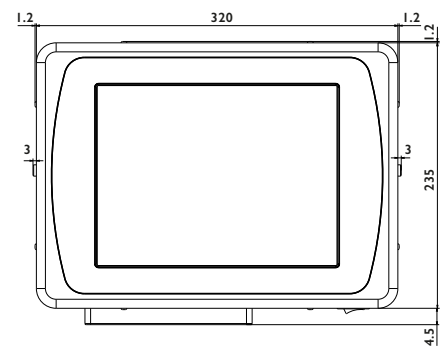

Printer bracket

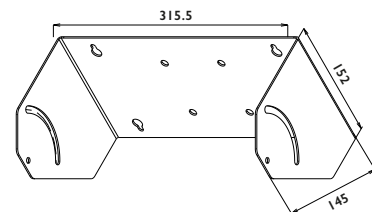

Gx-Series print head

