

Technical Specification:

	V230i (32mm)	V230i (53mm)
Printer Specification		
Printing Modes	Intermittent and Continuous in the same printer	
Left hand / Right hand	Both options available (convertible with no extra parts in 15 minutes)	
Print resolution	300 dpi	
Maximum print area (IM)	32 mm x 55 mm	53 mm x 55 mm
Maximum print area (CM)	32 mm x 500 mm	53 mm x 500 mm
Print speed (max) (IM)	400 mm/s*	
Speed range (CM)	10 mm/s – 750 mm/s*	
Print repeat rate (max)	6 prints / s (with a 10mm long print)*	
Ribbon drive technology	i-Tech Ribbon Drive with unique Dancing Arm tension control	
Max ribbon length	770m (up to 1925m effective length with Economy Mode)	
Standard Ribbon widths	34 mm, 22 mm	55 mm, 34 mm
Ribbon save modes*		
Economy Mode	Variable in 1% increments up to 60%	
Retraction Mode	Less than 1 mm gap between prints	
Column Mode	Yes	
Stop mid print	Yes	
Print features		
Date code format	Yes	
Offsets	Yes	
Shift codes	Yes	
Serial number generation	Yes	
Fonts	Most true type fonts	
Dynamic bar codes	Yes	
2D codes	Yes	
Database linking	Yes	
Logos / bitmaps	Yes	
In-field text highlighting	Yes – via QuickDesign Lite	
Graphical User Interface	QuickStep , full colour Interface Intuitive navigation via, large, easy to read buttons and Icons. WYSIWYG print preview. Multilanguage support.	
Controller options	No dedicated controller required. Options: • Domino TouchPanel (10.4") • Domino TouchPad (5.7") • PC based interface (via Ethernet cable or network)	
Connectivity	Ethernet / USB x 2 / mini USB (service)	
Inputs	Print Go, Encoder	
Outputs	Error; Ready; Ribbon Low; Spare (software configurable volt free contacts)	
Special features	Master slave, macros, password, fastmode	
Label creation	Onboard and via QuickDesign Lite (PC application included)	
Electrical requirements	90v – 264v AC 50/60Hz, OR 24v DC (+/- 2%) at 5A (if direct)	
Dimensions	(W) 218mm x (H) 160mm x (D) 172mm	(W) 218mm x (H) 160mm x (D) 193mm
Weight	6.9kg	7.5kg
TouchPanel Specification		
Type	10.4 inch, full colour touchscreen (800x600 resolution) VESA mountable with optional brackets	
I.P. Protection	Certified to IP65	
Connectivity	2 x USB, Ethernet	
Electrical requirements	100/240 VAC, 50/60 Hz	
Dimensions	W 307mm x H 232mm x D 75mm	
Weight	2.8kg	
TouchPad Specification		
Type	5.7 inch, full colour touchscreen (640x480 resolution). Handheld with docking station included.	
Connectivity	USB, Ethernet, Mini USB (for power / data connection to printer)	
Dimensions	(W) 173mm x (H) 128mm x (D) 34mm excluding docking station, (W) 181mm x (H) 135mm x (D) 50mm including docking station	
Weight	0.4kg	
PSU Specification		
Standard:		
Dimensions / Weight	W 67 mm x H 34 mm x D 166 mm / 0.4kg	
Cable length (PSU to printer)	1.2m	
Optional Industrial Long Length:		
Dimensions / Weight	W 117 mm x H 217 mm x D 63 mm / 1.0kg	
Cable length (PSU to printer)	2.8m	
Environmental requirements	Temperature: 5°C to 40°C. Humidity: 20-80%, non condensing	

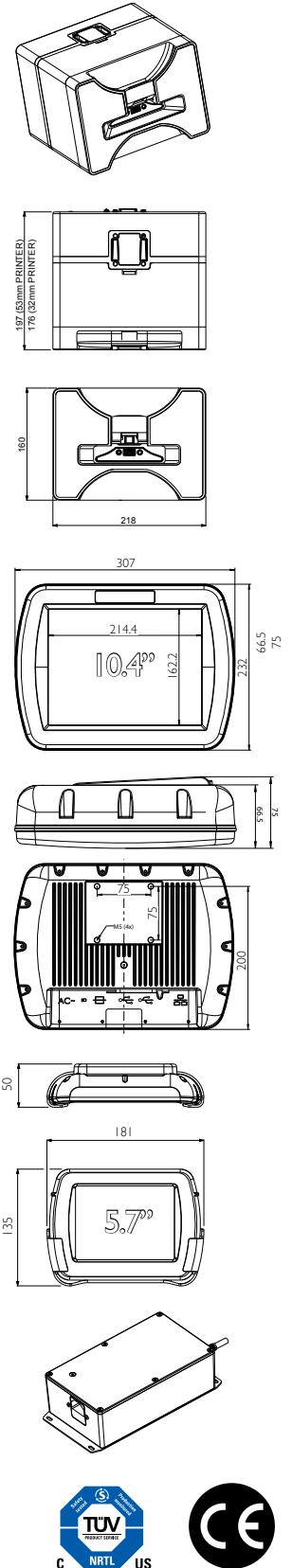

*Note: Capability is dependent upon application and substrate type as well as message length

www.domino-printing.com